

DENVER

be clever











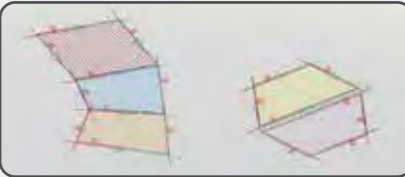
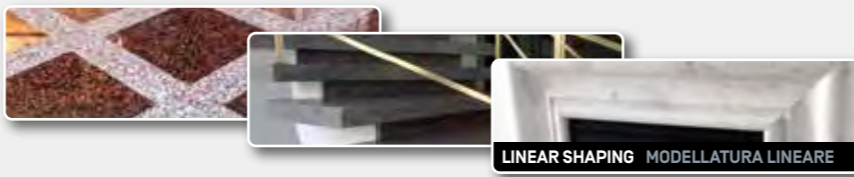

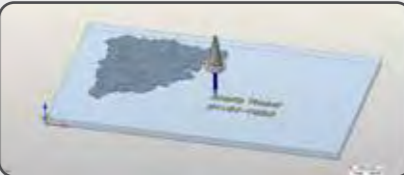
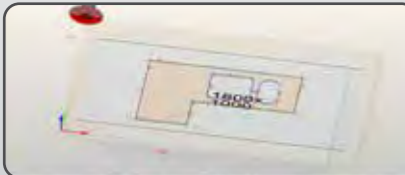
tecnika evo

5 axes bridge sawing machine **Fresa a ponte a 5 assi interpolati**

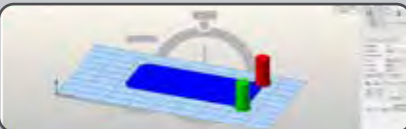
tecnika EVO is the new 5-axis interpolated cutting center specifically designed for processing natural and engineered stone, quartzite, ceramic and ultra-compact materials fully meeting the very parameters - speed, accuracy, working strokes and software interface - required for all tasks connected to efficient slab fabrication encompassing trimming, de-tensioning cuts, mitering, multidirectional and curvilinear jobs, as well as inner cut-outs.

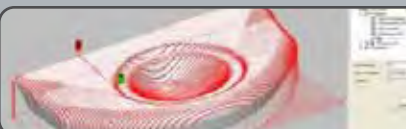
tecnika EVO è una fresa a ponte CNC monoblocco polivalente a 5 assi interpolati, che esegue molteplici lavorazioni con disco e utensile, su lastre e blocchi di pietra, marmo, granito e materiali artificiali (quarzo, ultracompatto, ceramica e gres porcellanato) di qualsiasi dimensione e spessore. L'obiettivo è soddisfare la crescente domanda di nuovi prodotti per l'edilizia e le costruzioni. Quarzite, gres e materiali artificiali ultracompatti sono disponibili in lastre con dimensioni e spessori in continuo aumento, per cui si richiedono tecnologie di taglio efficienti, flessibili e convenienti.

<p>Right-angled cuts Tagli ad angolo retto</p>  <p>MANUAL CUTS TAGLI MANUALI</p>	<p>Diagonal cuts Tagli diagonali</p> 	 <p>LINEAR SHAPING MODELLATURA LINEARE</p>
<p>Radius and circle cuts Tagli circolari</p> 	<p>Engraving Incisione</p> 	
<p>Sink and corner cut-outs Lavelli e aperture angolari</p> 	<p>Tilted cuts 45° Tagli inclinati 45°</p>  <p>AUTOMATIC AUTOMATICO</p>	 <p>VEIN MATCHING CORRISPONDENZA VENATURE</p>  <p>SINK CUT-OUTS APERTURA LAVELLI</p>
<p>Moulding Modellatura</p> 	<p>Surface finishings Rifiniture di superficie</p> 	
<p>Solid blocks Lavorazione di blocchi</p> 		

Heavy-duty, monobloc hot zinc coated basement.

Robusto basamento monoblocco in acciaio zincato a caldo.

Rustproof, soundproof and ergonomic bellows and guards to protect sliding parts and guides.

Guide e parti di scorrimento opportunamente protette con carter in ABS e soffiotti per una efficace insonorizzazione ed ergonomia d'uso.

Front safety doors and pendant control panel offering wide visibility and ease of use.

Porte frontali di protezione e quadro comandi pensile a ampia visibilità e praticità d'uso.

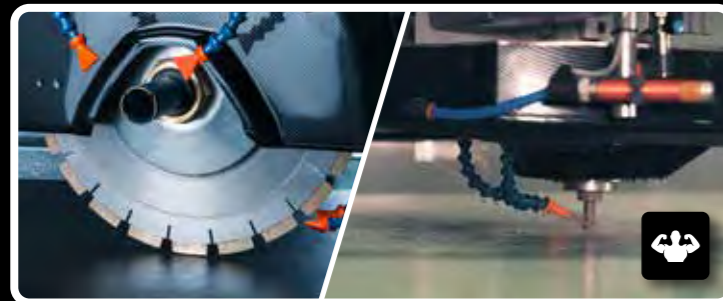

Kw 13 Main Spindle Motor

With adjustable speed till 6000 rpm's, complete with interchangeable Easyspin insert with 1/2 gas right thread. It allows the fitting of bit tools with internal water lubrication.

Motore principale Hp 17.5

A velocità regolabile fino a 6000 giri/min, completo di inserto intercambiabile Easyspin con foro 1/2 gas destro, e giunto per lubrificazione interna.

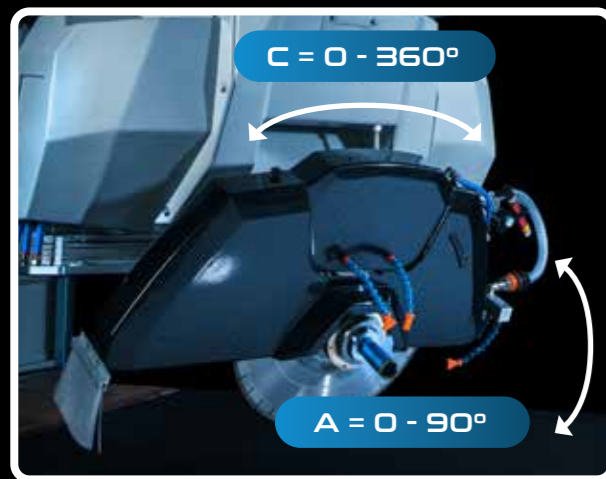

Interpolated auto head inclination for perfect miter and tilted cuts. Inclinazione automatica della testa interpolata per tagli obliqui e inclinati perfetti.

Interpolated auto head rotation for straight, diagonal and radius cuts. Inclinazione automatica della testa interpolata per tagli dritti, diagonali e circolari.



Auto Touch Probes

For slab thickness detection. For measuring disc diameter and tool length.

Tastatori Automatici

Per la misurazione dello spessore della lastra. Per la misurazione del diametro disco e della lunghezza utensile.



Tilting Table

Hydraulically driven, for safe and easy loading of the slab. Tilt capacity 2500 kg / 5500 lbs

Tavolo Ribaltabile

Azionato da pompa idraulica, per il caricamento della lastra in maniera agevole e sicura. Portata 2500 kg



TFS (Table Folding System)

The bench can be quickly manually adjusted still allowing the tilting of slabs and cutting operations, allows processings directly on the ground. Maximum tool length 270mm / 10.6"

TFS (Table Folding System)

Innovativo sistema che permette di escludere parte del banco di lavoro. Con una semplice e rapida operazione manuale, è possibile predisporre la macchina per eseguire lavorazioni a terra. Lunghezza massima utensile 270mm



Cross Laser

To ease the location and storage of the origin position and of the work piece dimensions and position, as well as digitizing templates.

Laser Puntatore a Croce

Per rilevamento e memorizzazione origine lavoro e geometria/posizione del pezzo da lavorare. È altresì utile per la scansione e digitalizzazione di sagome.

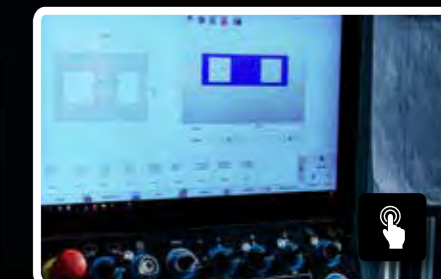

Make it easy with Logitouch software powered by DDX

To run semi- and fully automatic cut cycles and profiling, including DXF importability.

Semplifica il lavoro con il programma Logitouch by DDX

Per cicli di taglio e profilatura auto e semi-automatici. Include l'abilità di importare DXF.



X-Motion System
Vacuum system with 2 independent cups, for cut cycle optimization through automatic placement of the pieces.
Manipolatore X-Motion
Manipolatore a 2 ventose indipendenti per ottimizzare il ciclo di taglio mediante spostamento automatico pezzi.

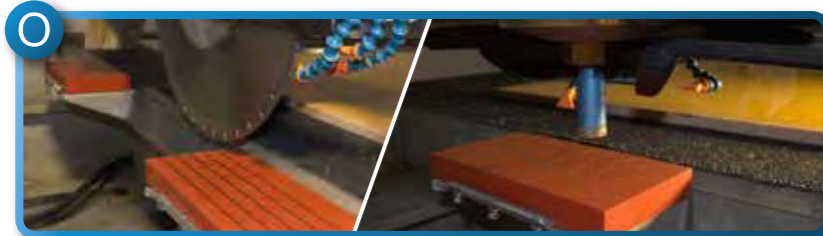

Redressing Devices for Disc and Core Drill including Automatic Management Software
Gruppo ravniva Disco e Foretto comprensivo di Software di Gestione

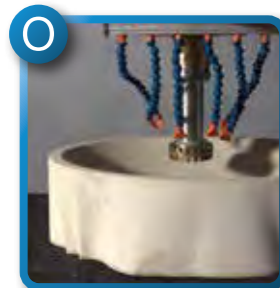

Adapter Device for mounting Heavy-Duty Tools
Dispositivo per il Montaggio di Attrezzature e Utensili per Lavorazioni Gravose tipo Scavo Masselli e Vasche



Spring-Loaded Head for Surfaces Honing and Leathering
Gruppo per Anticare, Levigare e Spazzolare Superfici Piane

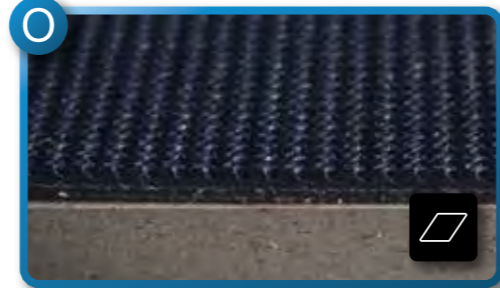

D-Grip Table Cover
Polyurethane table covered by rubber mat.
• High density
• Not sensitive to moisture
• Not decomposable
• Mold resistant
• Milled to ensure flatness over time.

Rivestimento Tavolo D-Grip
Piano di lavoro in poliuretano rivestito in gomma.
• Ad alta densità
• Insensibile all'umidità
• Non decomponibile
• Resistente alle muffe
• Fresato per garantire la planarità nel tempo.



Piggy-Back
Piggy-Back allows you to carry out typical CNC operations on your Denver bridge saw. Piggy-Back is an integrated system for milling, drilling, carving and engraving, it features an ATC (automatic tool change) electrospindle with ISO40 connection, vertically positioned on the side of the main motor for disc, the latter equipped with an 1/2" gas attachment.

Piggy-Back
Piggy-Back ti permette di realizzare le lavorazioni tipiche di un CNC sulla tua fresa a ponte Denver. Piggy-Back è un sistema integrato per eseguire lavorazioni con utensili, prevede un elettromandrino ATC (automatic tool change) con attacco ISO40, posizionato in verticale accanto al motore principale per disco dotato di un ulteriore attacco per utensile.

Software Optional Opzionali Software



LOGITOUCH
powered by DDX
On Board Photo Software Package with Camera
For auto workpiece contouring, measuring and vein matching.
Pacchetto Fotografia a Bordo con Fotocamera
Per la misurazione e il rilevamento automatico del bordo lastra e corrispondenza venature.



PRO TECH
powered by DDX
Cad-Cam software packages powered by DDX
For multi-tasking programming of the fully automatic working cycles, both from the machine control panel or from a separate PC.

Pacchetti software Cad-Cam by DDX
Per programmazione multi-tasking di cicli di lavoro completamente automatici, sia dal pannello di controllo macchina o da un PC separato.

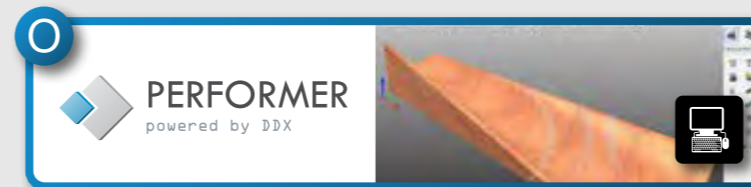

PERFORMER
powered by DDX
Cad-Cam software package for tridimensional processings
Pacchetti software Cad-Cam per lavorazioni tridimensionali

COMPACT FOOTPRINT INGOMBRO COMPATTO

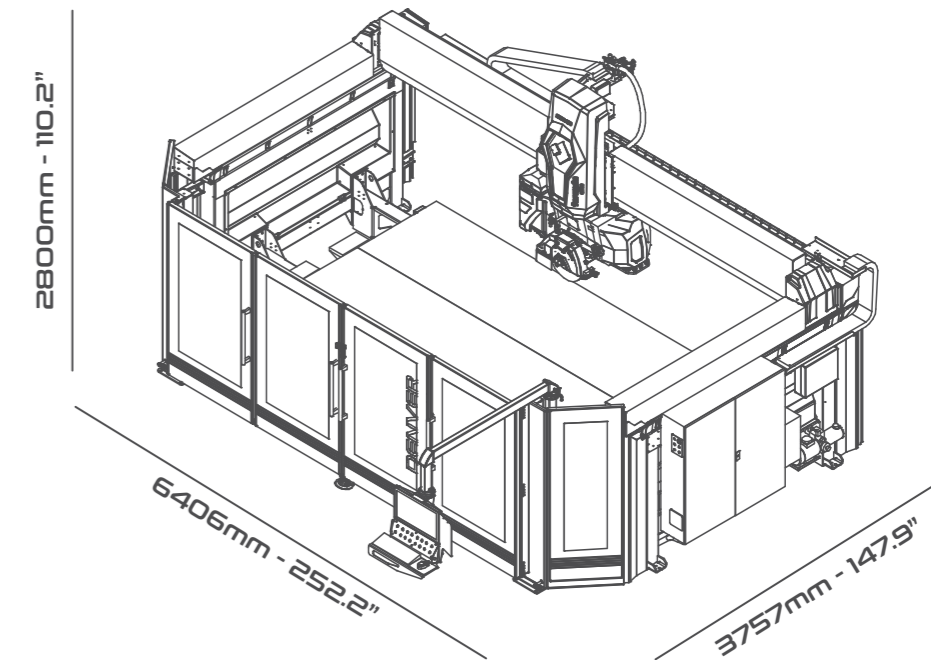

Main motor power
Kw 13 - Hp 17,5 (S6)
800 ÷ 6000 rpm

with right-hand threaded
1/2" gas connection
con attacco
1/2" gas filettato destro

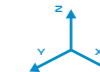

X 3700 mm - 145,7"
Y 2650 mm - 104,3"
Z 370 mm - 14,5"



A axis
0-90°
C axis
0-360°



Weight
3800 kg
8400 lbs



Disc diameter
350÷625 mm
13 ÷ 24"

PATENTED



be clever
be innovative
be human
be part of Denver World

DENVER è il centro di eccellenza tecnologico che vuole guidare lo sviluppo della San Marino Tech Valley, ispirato da una mentalità che persegue da sempre l'eccellenza che è profondamente radicata nella nostra cultura aziendale.

DENVER è uno stile di vita volto all'eccellenza e alla costante curiosità, che significa crescita, progresso e soluzioni che fanno la storia del settore.

Vogliamo trasmettere questo senso di eccellenza al cliente che scegliendoci entra a far parte di **DENVER WORLD**, e questo per lui significa fare la differenza sul mercato rivoluzionando il suo modo di concepire il sistema di lavoro e il business.

"Di questi 40 anni di rivoluzioni e innovazioni mi prendo il solo merito di aver piantato il seme. Quello che è DENVER oggi è frutto del lavoro quotidiano delle persone che negli anni hanno fatto l'azienda e che hanno permesso che il mio sogno divenisse realtà."

DENVER manufactures machines for the stone and glass industries.

DENVER is the centre of technological excellence that aims at driving the San Marino Tech Valley's evolution, inspired by a mentality of excellence deeply rooted in our corporate culture.

DENVER is a lifestyle driven by ingenuity and constant curiosity, open to growth, progress and solutions.

By choosing us, you will join **DENVER WORLD**, experiencing a friendly team of people committed to your success and satisfaction.

"Of those 40 years of revolutions and innovative solutions, I only take the credit for sowing the seed. What Denver is today it is all thanks to those people who worked hard to make the company grow and to those customers who believed in us making my wish come true."

Presidente e Socio Fondatore

Alvaro Giannoni

Alvaro Giannoni



www.denver.sm

seguici su / follow us on:



DENVER financing

Financing, leasing and trade-in services for pre-owned machines.

Servizi di finanziamento, leasing, valutazione e permuta usato.

DENVER care

Warranty, spare parts and maintenance services.

Servizi di garanzia, assistenza, ricambi e manutenzione programmata.

DENVER training center

CAD-CAM training.

Corsi software CAD-CAM, aggiornamenti sulle principali lavorazioni.

DENVER solution center

700 m² of exhibition space, demonstrations dedicated to all machinery and to each type of processing. Online webdemo.

700 mq di spazi espositivi, dimostrazioni dedicate su tutte le macchine e per ogni tipo di lavorazione. Dimostrazioni online.



ASSISTANCE CONNECT



DENVER S.p.A. - Strada del Lavoro, 87 | 47892 Gualdicciolo, Rep. San Marino
Tel. +39 (0549) 999688 | Fax +39 (0549) 999651 | info@denver.sm



DENVER USA Inc.

142 Fox Knoll Drive, Unit D - Powells Point, NC 27966

info@denverusamachinery.com

www.denverusamachinery.com

Phone: +1 336 250 6590

DENVER WORLD